



US00D894054S

(12) **United States Design Patent**
Smirnov

(10) **Patent No.:** **US D894,054 S**

(45) **Date of Patent:** **** Aug. 25, 2020**

(54) **MOTORCYCLE**

(71) Applicant: **FUELL Inc.**, New York, NY (US)

(72) Inventor: **Artem Smirnov**, Minskaya Region (BY)

(73) Assignee: **FUELL Inc.**, New York, NY (US)

(**) Term: **15 Years**

(21) Appl. No.: **29/681,953**

(22) Filed: **Feb. 28, 2019**

(51) **LOC (12) Cl.** **12-11**

(52) **U.S. Cl.**
USPC **D12/114**

(58) **Field of Classification Search**
USPC D8/19
CPC B62J 11/00; B62J 25/00; B62J 25/04
See application file for complete search history.

(56) **References Cited**

U.S. PATENT DOCUMENTS

D400,827 S *	11/1998	Moore	D12/120
6,173,983 B1 *	1/2001	Moore	B62J 25/00 280/291
D493,134 S *	7/2004	McCoy	D12/223
D519,886 S *	5/2006	Colano	D12/114
D531,092 S *	10/2006	Stahel	D12/114
D532,341 S *	11/2006	Thomson	D12/120
D535,243 S *	1/2007	Andkjar	D12/223
D538,734 S *	3/2007	Reimitz	D12/223
D539,208 S *	3/2007	Reimitz	D12/223
D568,805 S *	5/2008	Gallo	D12/535
D580,338 S *	11/2008	Blake	D12/223

D639,213 S *	6/2011	McElroy	D12/114
D662,862 S *	7/2012	Schutz	D12/114
D687,368 S *	8/2013	Takenaka	D12/535
D694,171 S *	11/2013	Itoi	D12/535
D736,142 S *	8/2015	Delhommeau	D12/534
D737,732 S *	9/2015	Stockett	D12/120
D755,683 S *	5/2016	Goodlow	D12/114
D772,774 S *	11/2016	Yuan	D12/223
D779,412 S *	2/2017	Otani	D12/535
D782,395 S *	3/2017	Vowles	D12/535
D834,456 S *	11/2018	Shelton	D12/114
2006/0181054 A1 *	8/2006	Colano	B62J 25/00 280/291

* cited by examiner

Primary Examiner — Michelle E. Wilson

Assistant Examiner — Clese Moore, Jr.

(74) *Attorney, Agent, or Firm* — Banner & Witcoff, Ltd.

(57) **CLAIM**

The ornamental design for a motorcycle, as shown and described.

DESCRIPTION

FIG. 1 is a front, right perspective view of a motorcycle showing my new design;

FIG. 2 is a right side view thereof; and,

FIG. 3 is an enlarged view of FIG. 1 with some environment removed for clarity.

The broken lines immediately adjacent to the shaded area define the bounds of the claimed design and form no part thereof. The broken lines depicting the remainder of the motorcycle show features that form no part of the claimed design.

1 Claim, 3 Drawing Sheets

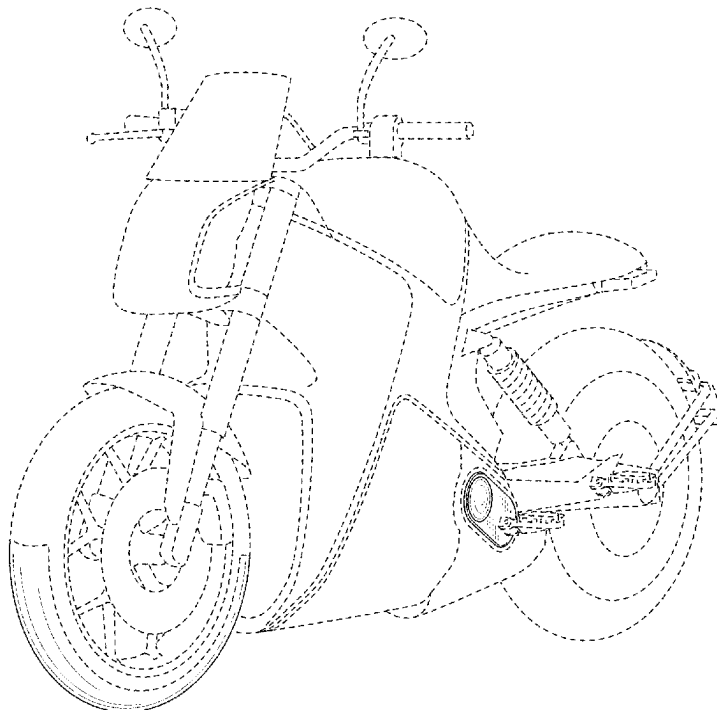

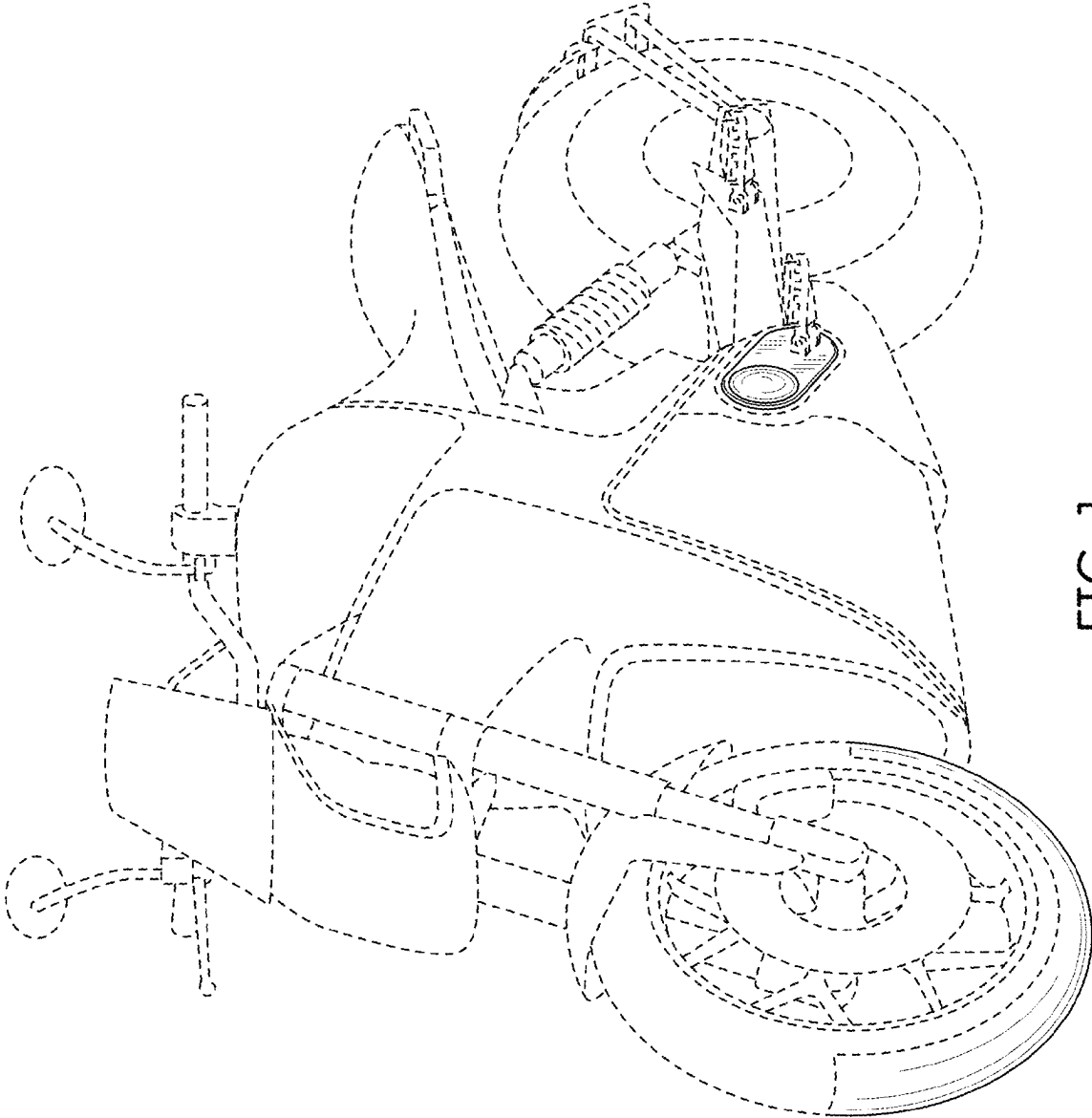

FIG. 1

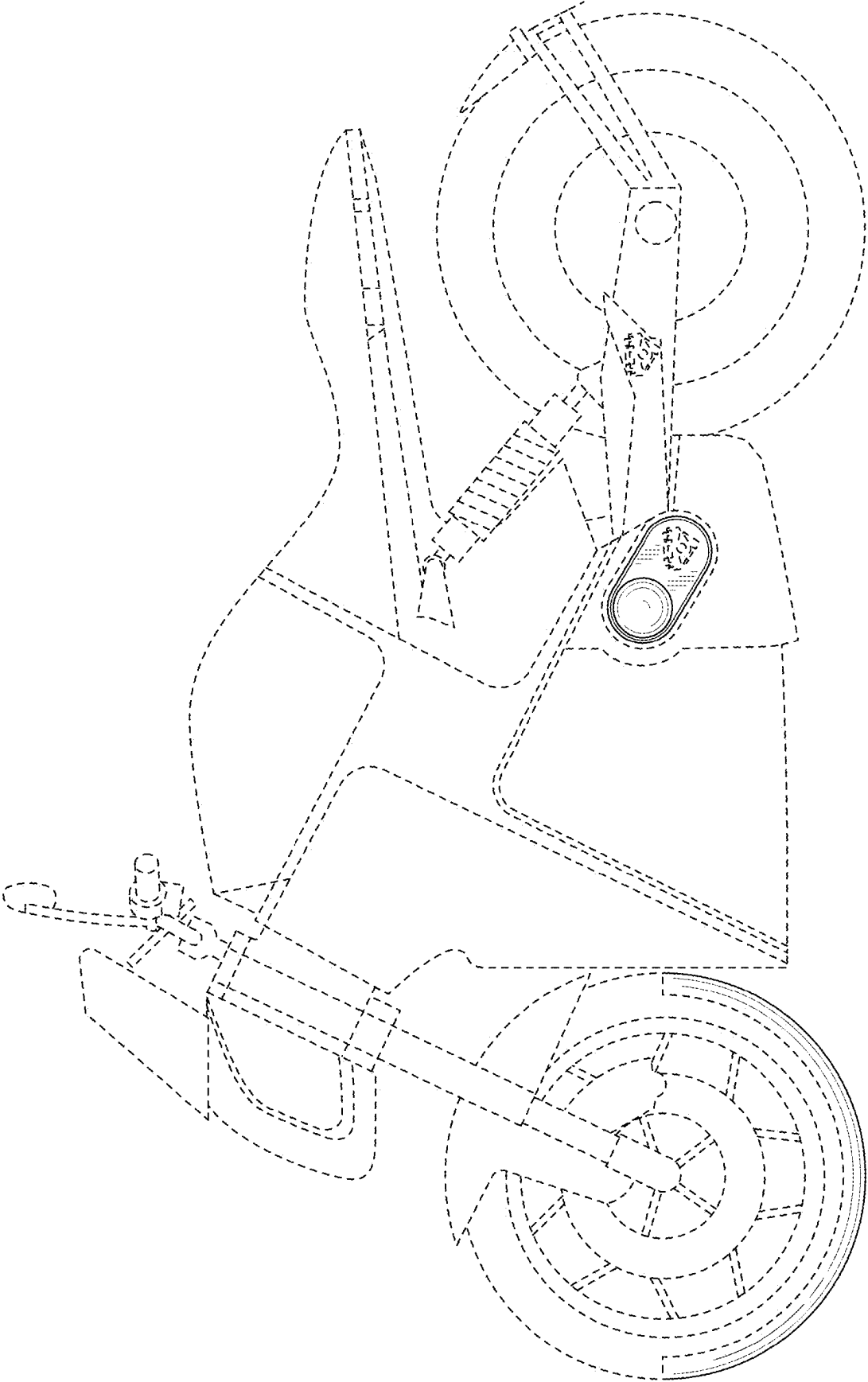

FIG. 2

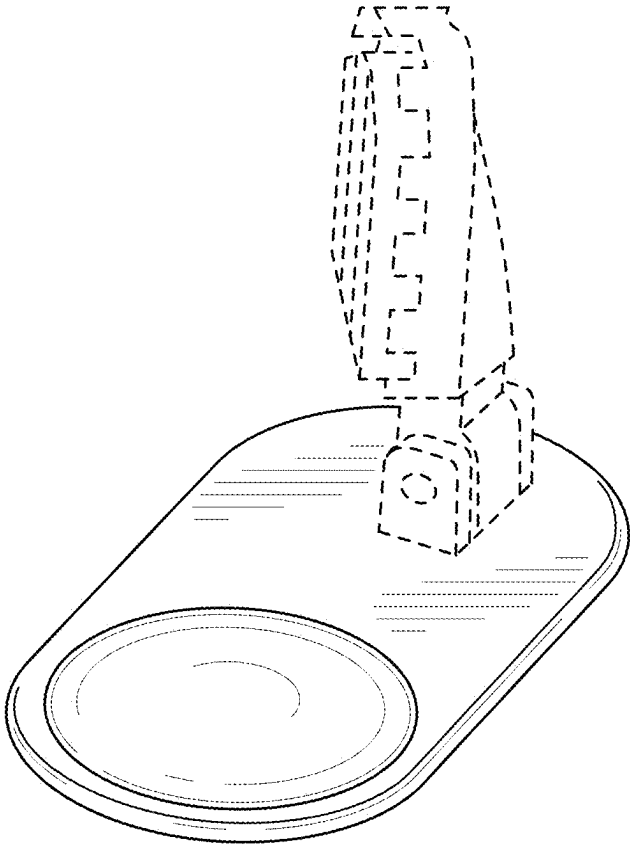

FIG. 3